

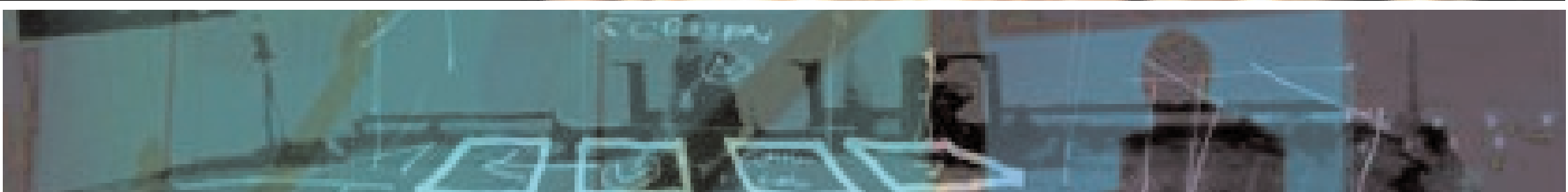

a rough ride through imaginary spaces, places and rooms

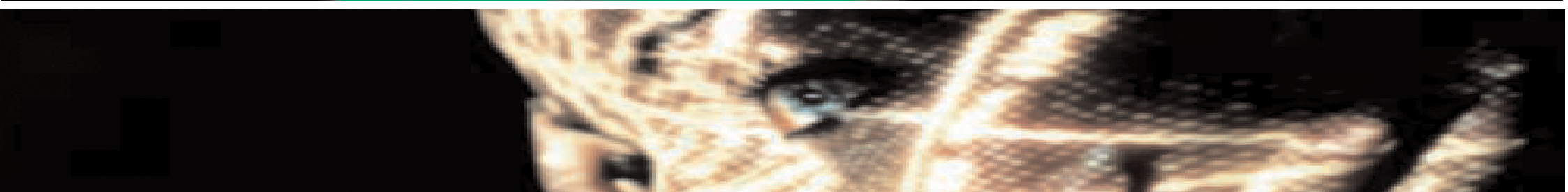

[] [R] [O] [O] [M] [S] []



nomad



46 sequences

9 people

ROOMS

Rooms – a rough ride through imaginary spaces, places and rooms.

nomad.theatre presents a dynamic installation – a hybrid of acoustic, visual fragments and performative loops.

Music, performance, dance, language, objects and visuals – fragmented, dissociated –taking (their) place, taking the stage as dynamic installation. fragments constantly shifting, changing shape, interacting, recurring in parallels, thereby creating room for dialogue, for negotiation. Miniatures appearing, disappearing. At least it seems so.

The moment is intensified by its repetition but in the very same second trailing away to single snap-shots. The components of perception meet on common playgrounds. But right in the vacuum of the associated and the perceived, imagination is reconstructed. Perspectives on reality adjusted.

Experience, memory, association, their strings, their rooms, their point of collapse.

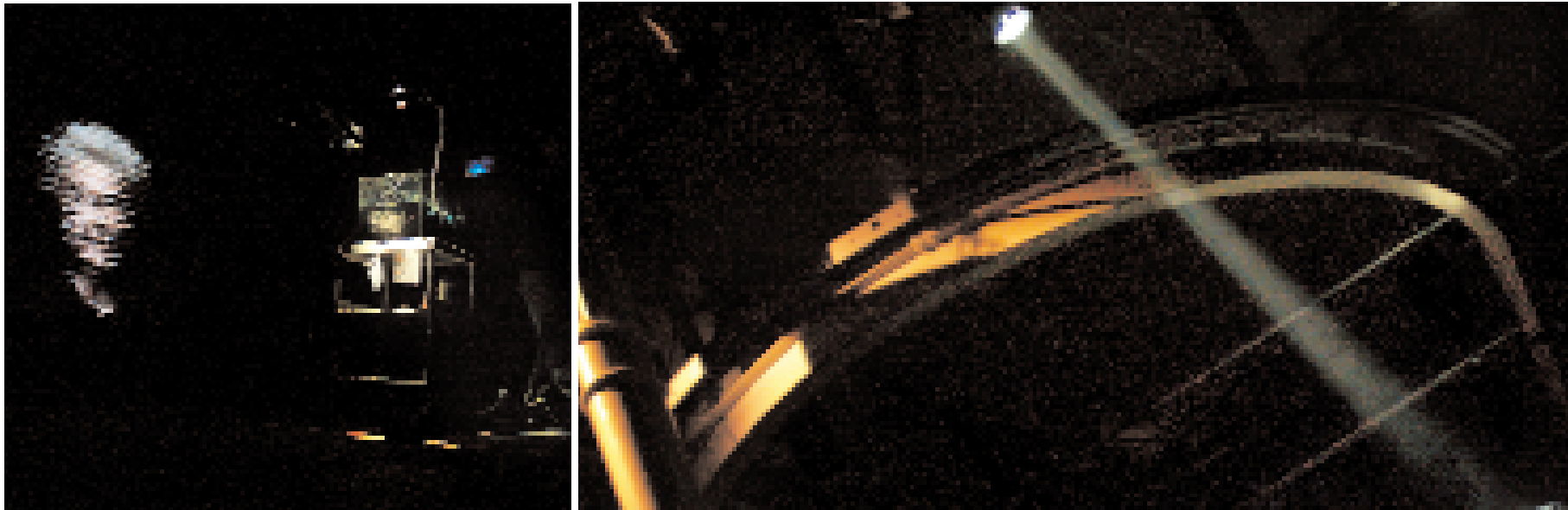

Team: 9 people

concept/direction/general installation: Thomas Jelinek.

composition/sound environment: Art Denissov.

assistance and visuals: Ruth Schmid. **performance/living installations:** Magda Loitzenbauer, David Kleinl, Zeynep Buyrac, Harald Jokesch, Yolanda Espinoza, Anna Scheer. **stage camera / life video:** Anna Scheer.

life musician: David Kleinl.

ABSTRACT

ROOMS is always shifting, blurring, emerging and adaptable. The concept reacts to each particular room situation and will be adjusted to each individual venue. Each performance is unique

The rooms project combines two interwoven components:

Installation

The installation consists and feeds from trivialities, everyday items, common objects, which will be placed on square pads – just like blackboards, you can write on with chalk – so the visitor can use chalk himself to continue or rewrite hi/story.

Sound loops of different durations appear to be one of the most important components. Coming from diverse sources and speakers spread across the pads, they create certain patterns of sounds and associative sound spaces.

During the installation-time, single pads, in their function as a separated spaces, will become ,active' in irregular sequences – being played by performers or automatically. The single spaces of the installation act interactively, depending on their character.



Performance

60 minutes – multilingual performance.

The installation consists of persons, characters and living objects. moving, processing they (inter) act, speaking in altered, shifting loops which always come out differently to how they have been expected.

A performative relapse is a dynamic installation is an acoustic montage is a living exposition is a hysteric fragment is a series of reconstructed miniatures.

Room-Constructions. Disassociated. Not only the theatrical paradigms, also the components of perception are being set into the room as deconstructed, separated and fragmented.

A journey between the moments of hope that appear to be infinite and the constrictions of the ,panic room' - the drumfire of archaic metaphors, that steadily buzzes around us, the rhetoric of ,endism' – the decline, the final loss, the permanent state of emergency.

The political space of the recursive loop, in which the individual components build up far into profundities of our culture. A cage in which we search for shelter against irrational fears – apparently beset by an uncertain reality.

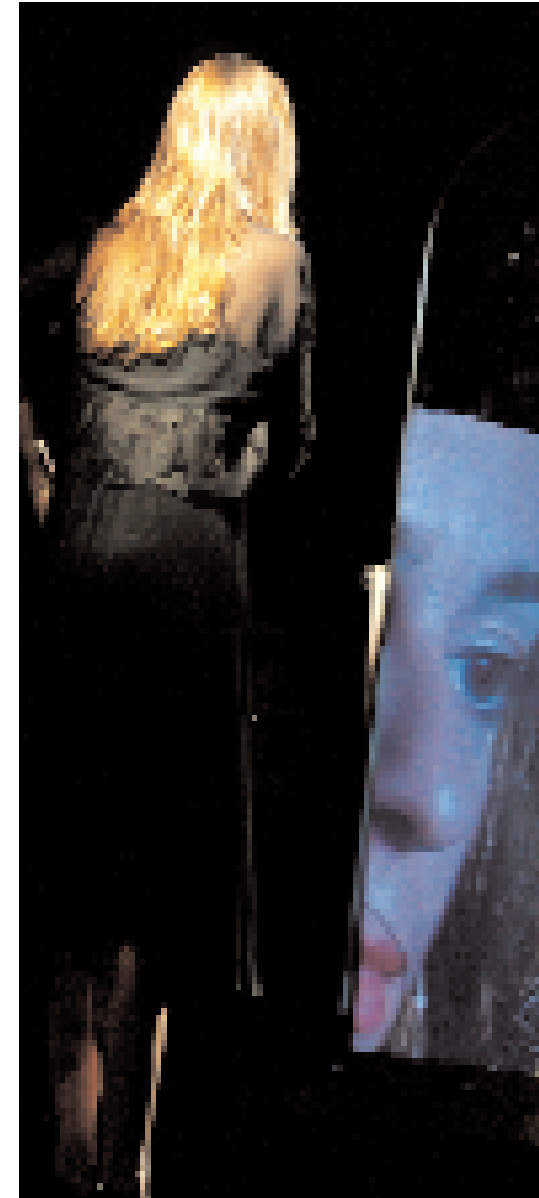

ABSTRACT

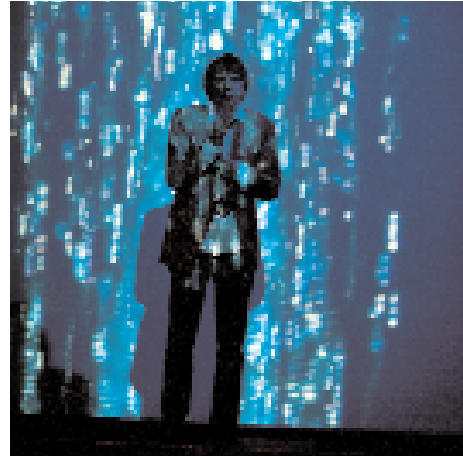
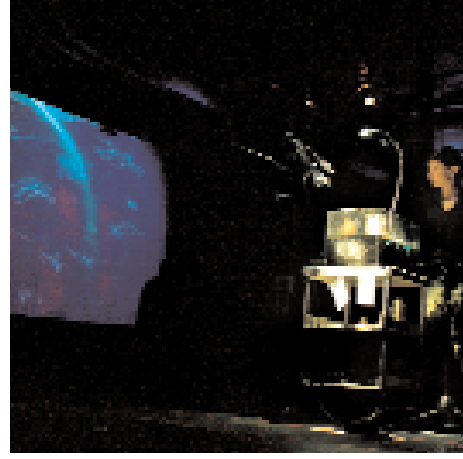

PICTURES

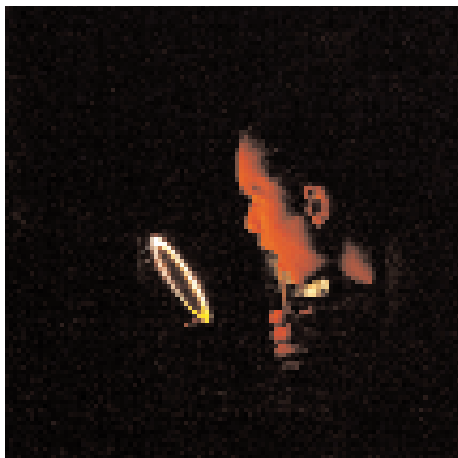
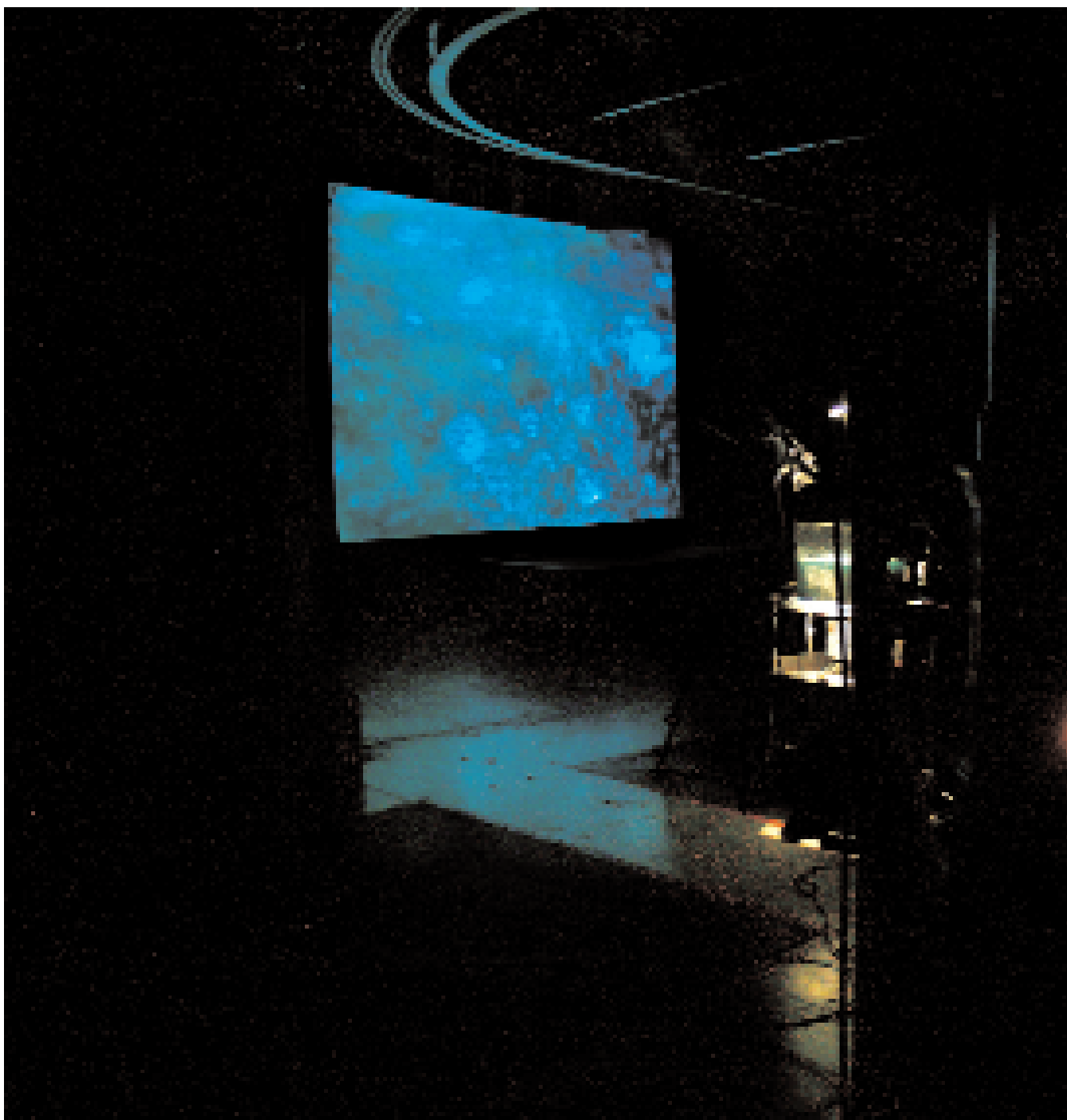

PICTURES



„A performance like a David Lynch movie ..."

„In front of the eyes of the spectator an abysmal complex universe builds up that immediately ignites fireworks of associations."

„In dealing with what has been seen and heard one finds himself on a explorative journey into the depth of his own consciousness...just as the programme promises."

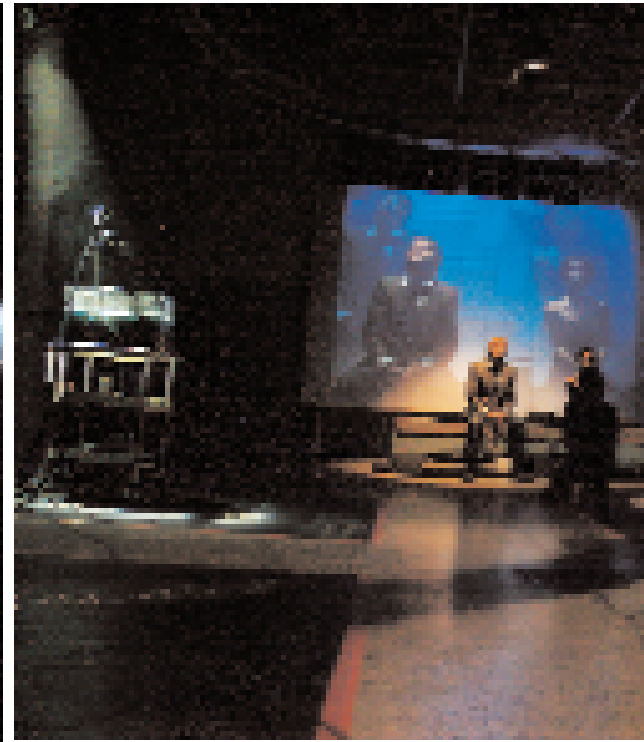
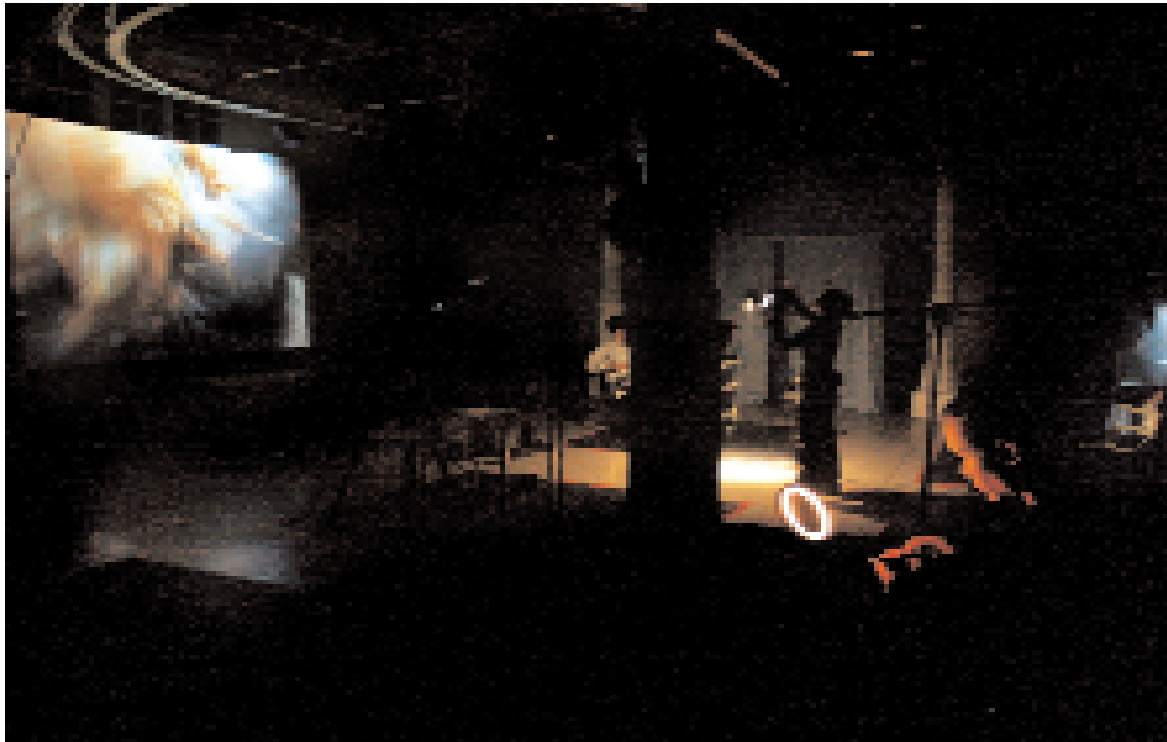

„...much more disquieting than the plot, the sound works by Art Denissov forge ahead to the marrow"

„Jodorowsky was, in some respect, an inspiration. Although the iconography seems more difficile – sometimes banal. But violent in a similar way. Or even violating."

COMMENTS

Draft

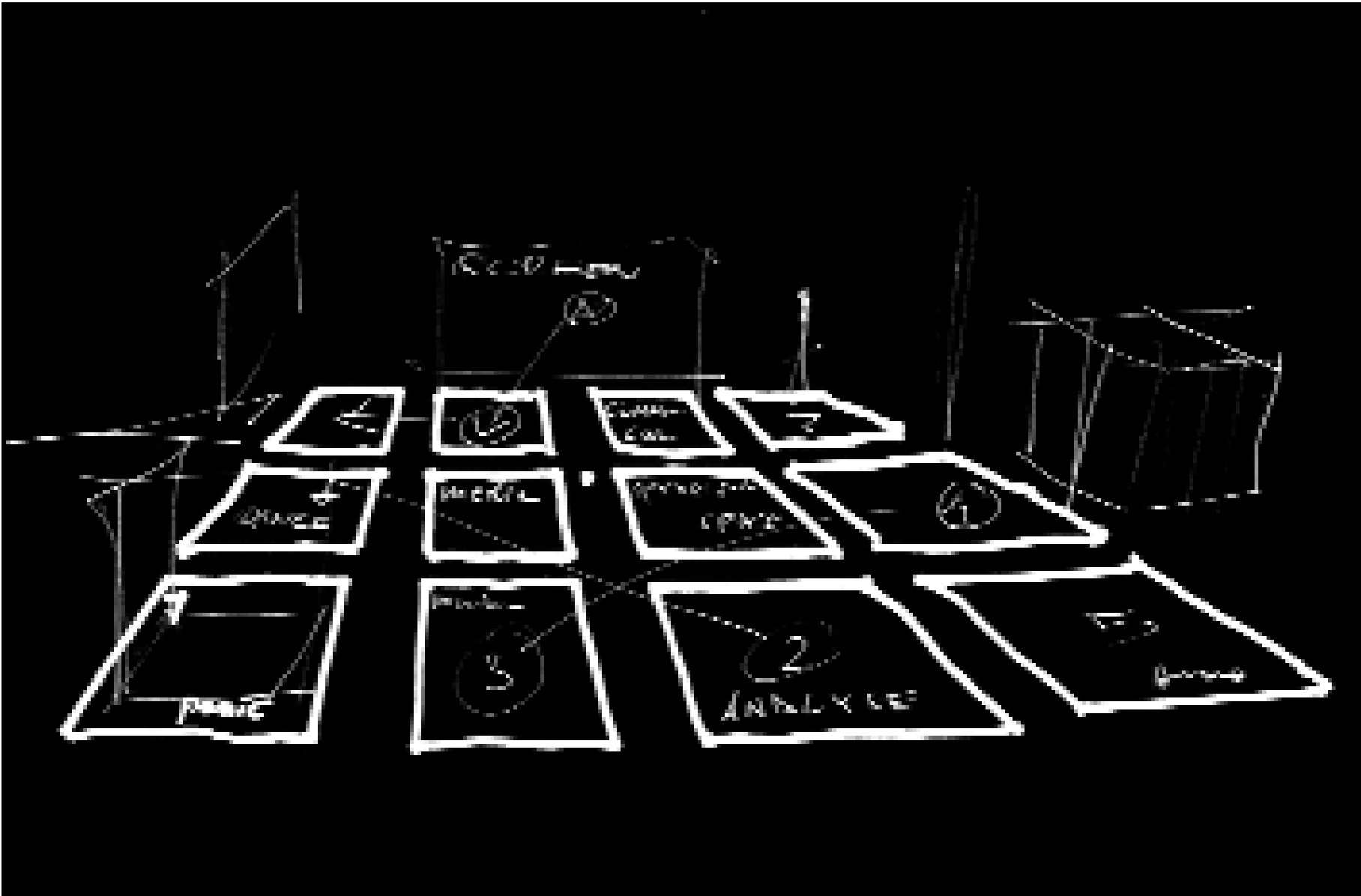

TECHNIC

Plan

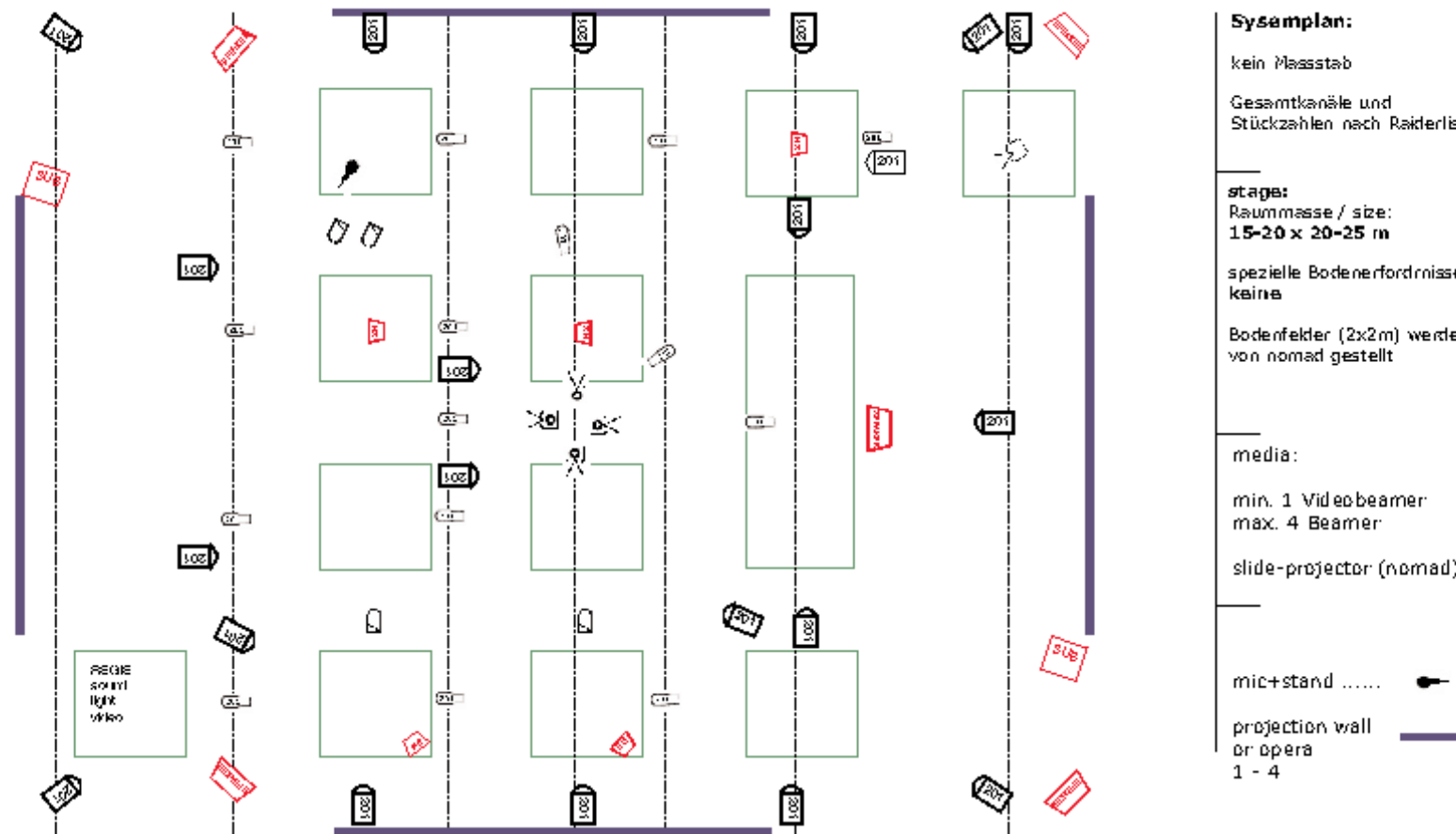

Sysamplan:

kein Massstab

Gesamtkanäle und Stückzahlen nach Raiderliste

stage:

Raummasse / size:
15-20 x 20-25 m

spezielle Bodenerfordnisse:
keine

Bodenfelder (2x2m) werden von nomad gestellt

media:

min. 1 Videobeamer
max. 4 Beamer

slide-projector (nomad)

mic+stand 

projection wall
or opera 
1 - 4

nomad

title prod:
ROOMS

sound

speaker
mini speaker
subwoofer

lightmap:

15 Profile / Filter : 201
4 PC 2K
17 PC 1K
8 PAR 64 1K

Regie: Thomas J. Jelinek

projection:

video-beamer
slide-projector



TECHNIC

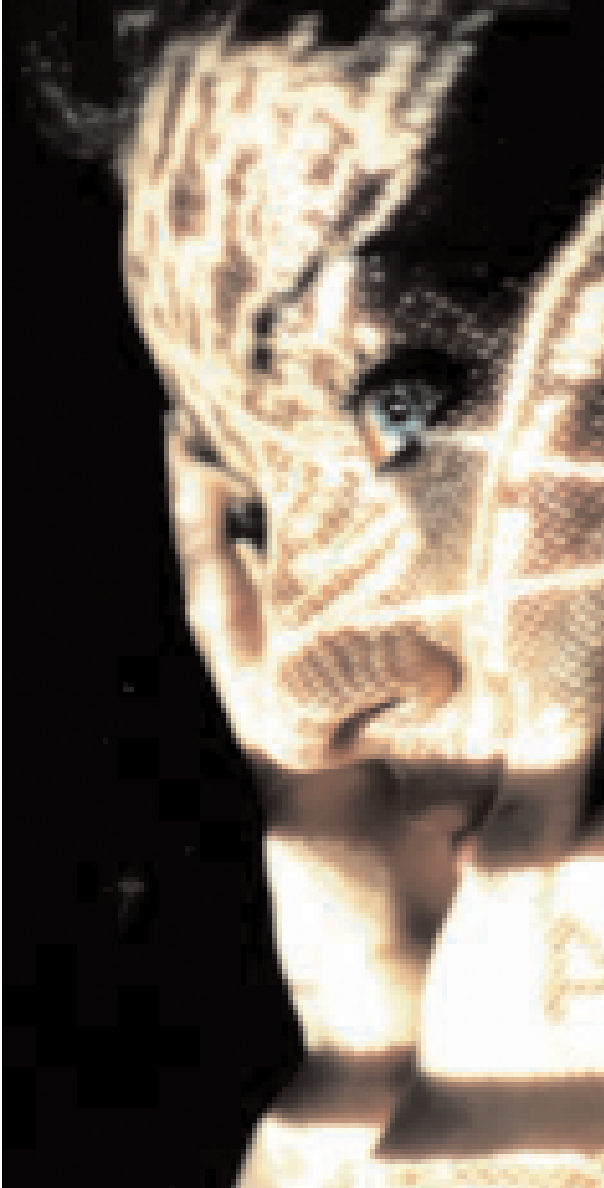

nomad.theatre focuses on the development of contemporary forms of communication and expression, as well as on transdisciplinary projects in a performative, situational and the so-called theatral context.

Starting point will always be the creation of temporary spheres of action and structured spaces of communication.

The focus is set on the long-term, process-oriented projects, which are being elaborated in laboratory-like situations and are presented to the public as a variety of results evolving from the process.

nomad.theatre was founded 2000 by director Thomas J. Jelinek

process-oriented projects

Odysseus fragmente

>> fragment 0 installations<< TRANSART-festival 2000 (Labin/CRO) >>fragment 1 - Pressekonferenz<<, 2001 >>fragment 2 - Der Bauch des Pferdes<<, 2002, >>fragment 8 - Penelope<<, 2003.

serious POP project, 2003/04 a cooperation of LABfactory, dietheater Konzerthaus and: Fluc im Exil, nomad-theatre, RAHMENWERK, EU-eroticunion, Akademie d. bild. Künste Wien.

[camp!] project in cooperation with MASKA Ljubljana(SLO) Wagenhalle / ev. Büro für ungewöhnliche Sofortmassnahmen , Stuttgart(D) WdKA, Amsterdam (NL), V2 institute for unstable media , Rotterdam (NL) KICK OFF [supercamp], 2006, CAMP LAB 1, 2006, CAMP LAB 2, 2006

nomad.theatre



since 2007 **theSCREEN** experimental media-theatre & streaming project.

theater/performance productions (sample)

>>BLAU<< transcript v. Derek Jarman, >>Augustin<< 2001, >>Brammer sieht Schwarz<< 2002/03

please visit our websites for video and mediafiles.

since 2004 nomad.theatre maintains the venue **LAB**factory transdisciplinary working, - presentation,- and cooperation-platform for various groups, artists, individuals working in media, performance, dance and fine art.

kontEXtLab and performingLAB

2006 >> high : water : mark <<, >> camp : fire : stories <<, >> sprech : platten : battle <<, >> poetry for androids - binäre transkription <<, >> MEDEAKOMPLEX :: schwarze witwen <<, >> The Sputnik Re-Enactment / Pilote <<, >> Name of the Game - diskurs am ball<<, >> superflat - performance in der 2ten dimension<<, >> fünf vor fünf - wahl lab <<, >> web nomadism - virtually alive <<, >> 1. Abendmahl << **2007** >> utopia - future visions <<, >> two days after - Stanislav Lem <<, >> permanent red <<, >> Lela's Code - the day I had an affair with technologies <<, >> Blade Runner - everybody's favorite movie <<, >> Delirium <<, >> virtual cities - virtual life <<, >> public affairs <<, >> Path-oh!-Logies II <<, >> 2. Abendmahl <<, **2008** >> InterAktives Orakel <<, >> panic room - hysteria 08 <<, >> der Tod und das Mädchen <<, >> My first Burial <<, >> I was a teenage pornstar <<, >> The Innermost Unifier <<, >> white room 1 - kick off <<, >> BEN HUR <<, >> BEN HUR 2 Jack Black <<

the serial program is accompanied with various panels, talks or discursive formats as durch **openLAB**, >>**olfactory** - olfaktorische Reise << or others.

current projects

>>ROOMS<<, start 2008, >>BLAU<< Tour,
>>A Brief History of Time<<, >>the SCREEN.tv<<
media-art-platform.

for details please visit

www.nomad-theatre.org
www.labfactory.at

ABOUT

Thomas J. Jelinek

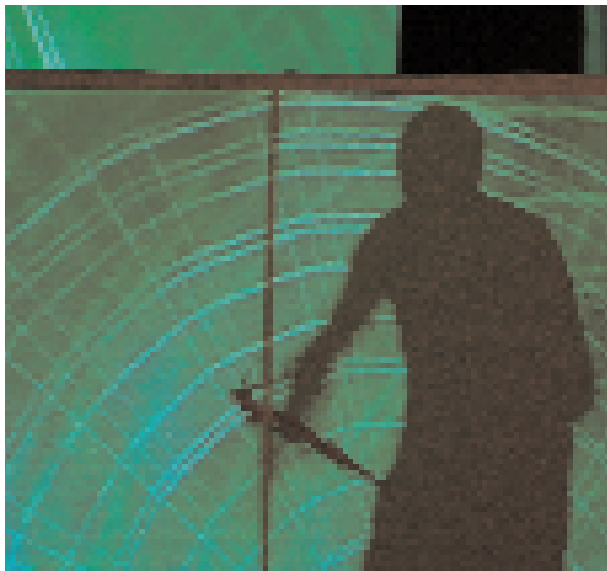

born in Stockholm

Director, dramatic advisor, curator, video/installation-concept-art

Artistic director of LABfactory and nomad.theatre

Co-founder and dramatic advisor of liquid.loft

From 2000 to 2008 chairman of IG Kultur Wien

Video- and room- installations, musical performances, architecture projects, curator (among others) LOGBUCH (Berlin), Projekt-Niemandland, „E55.project“ (MESSING network/nurSchrec/WUK) and international TRANSART-Projekt u. TRANSART-Lab.Festival 2000 in Croatia; involved in a number of networking-projects in Europe, in ‚communications-rooms‘ and transdisciplinary laboratories. Initiation and involvement in East-West connecting- and exchange-projects, symposia e.g. „Guest in Europe“, Vienna-Bratislava Exchange.

Co-founder and conductor of MESSING network, directing- and concept work, performance- and theatre projects in public and theatral Spaces in Austria, Germany, (Tacheles/Berlin, Dresden, München etc.), Switzerland (Zurich/Basel), Netherlands, France, e.g. „Lifeline“ at Biennale Marseille. Projects with Fokus-Film-Theater: directing together with Harald Jokesch „BLAU“ from Derek Jarman, „Johnny got his gun“ from Dalton Trumbo.

Opera-production: PARADISO by Dante in Salzburg (summer academy Mozarteum/ Salzburg Festival); conceptual work and stage direction for video installations, various video- and TV-productions among others for ORF/Kunststücke. Founder of nomad.theatre and LABfactory. Projects: Ulysses.factory/direction for ODYSSEUS-fragmente: Theatre series „fragment 1 – Pressekonferenz“, „fragment 2 – der bauch des pferdes“, „fragment 8 – Penelope“ (co-production: dietheater Künstlerhaus, Wien), 2005 Co-founder of liquid.loft with Chris Haring, Andreas Berger (music) und Stephanie Cumming (dance).

2005 Dramaturgy liquid.loft/Haring, 2006 camp-project with Alexander Nikolic, Katherina Zakravsky (nomad.theatre and Partner MASKA (Ljubliana/SLO), WdKA, V2 (Rotterdam/NL) Wagenhalle ev/Buero f.u.M. (Stuttgart/D) etc.). Visiting professor at Willem de Kooning Academy / free art / media (Rotterdam/NL). Since November 2004 participation and co-production in the international project „seriousPOP“. 2005 managing the konTEXTlab-series at LABfactory. Creation of various performance modules and of the WEB-TV project theSCREEN.

AWARDS:

„best play“ off-theatre at Donaufestival Krems / 1999 for „Johnny got his Gun“ (by Dalton Trumbo) for stage direction. „best short 2002“ Television award ORF-Kunststücke für direction of „Dantes INFERNO“. Dramaturgy: „best performance“ at Biennial de dance Lyon / 2004 for „Fremdkörper“ / choreography: Chris Haring. Golden Lion of Biennale di Venezia 2007 for „best performance“ of liquid.loft for „posing project B . art of seduction“ (dramaturgy).

Art Denissov



born in Saratov (UdSSR),
composer, sound designer, sound-concepts

Accompanying his piano- and conducting-studies in Moscow he co-founded and worked in the experimental studio for electronic art "Klebnikov Electronique".

1989 he was invited to contribute to „Ars Elektronica“ festival in Linz. 2000 he graduated his studies of composition with B. Schaeffer at „Mozarteum“ in Salzburg. He took courses for NEW MUSIC with L.Berio, F. Donatoni, M. Kagel and took part in „Genesis“, an audiovisual workshop with physical models led by L. Brummer at ZKM Karlsruhe/D.

Since 2001 member of the managing board of the international Paul Hofhaymer association and of the austrian ensemble for New Music (ÖENM).

With his compositions he attended the international festival for contemporary music „Aspekte“, the Elektrokomplex Festival, the Project „Ranin Al Autar“ (collaboration with soloists of the Cairo Opera and OENM), the ÖENM's „Night of the composers“, the „Long Night of the Museums“ at Künstlerhaus and at ARGE Salzburg with „Sampling Story“ (computer music and video).

He composed the soundtrack for „Tirana Year Zero“. In the production „Der Dichter und sein Dikator“ at Landes Theater Salzburg he worked as musical director. At Thalia Theater Hamburg he co-produced music for „Machiavelli“. He was involved in the sound works for „Udo77“ at Rabenhof Wien.

2004 his works have been shown at „MAK NITE spezial – Europa jetzt“ at Museum für angewandte Kunst Wien. With his play „Relationen, Teil I – Onda verde“ he participated in the ÖENM's project „Russland“ in summer 2004. He worked on the soundtrack for the movie „Kotsch“, a Lotus Film production.

Since 2003 Art Denissov lives and works in Vienna.

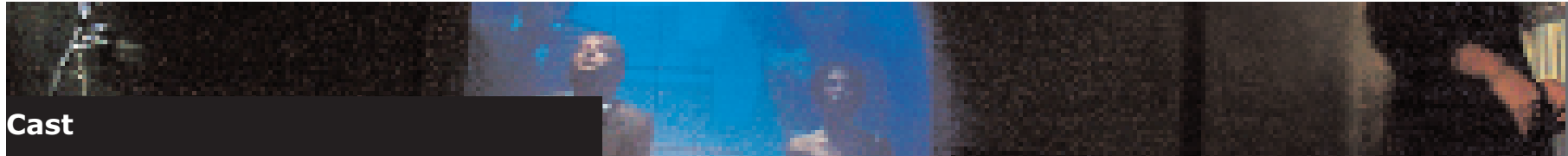

Cast

Zeynep Buyrac

born in Istanbul. Actor's training at the Conservatorium of the City of Vienna. Various theatre-productions at the Conservatorium, Engagements (among others) at: Theater der Jugend, Festspiele Burg-Liechten-Stein, Dschungel Wien City Theatre Mödling, Scala. Since 2005 Member of the Ensemble TzF. Cooperation with Thomas Jelinek in various konTEXTlab-productions since 2007.

Harald Jokesch

born in Graz. Actor, director, dramatic advisor. Training at Mozarteum Salzburg. 1984-1990 Wilhelmshaven and Hamburg. Works and lives in Vienna since 1990. Works among others in productions with the Aktionstheater Ensemble, Hubsi Kramar, Bruno Max. Since 1997 several collaborations with Thomas Jelinek, e.g. Odysseus, konTEXTlab 01 – 23, „BLAU“, „Johnny got his Gun“. Other own works „Fieber“ by Wallace Shawn, „Kelly Briefe“ by Wolf Wondracek.

David Kleinl

Freelance musician and video artist in the art-, theatre- and documentary context. Studies of visual media design at the University of Applied Arts Vienna. For „Rooms“ he acts as the singing Dandy – a figure created for the Pop duo Tanz Baby!, in which he performs in cooperation with Kristian Musser.

Magda Loitzenbauer

born in Santa Cruz do Sol. Freelance dancer and choreographer. Actress in „Empire“ – Superamas, the Toxic Dreams Musical „De Lady in de Tutti-Frutti Hat“ / „Generator“ – Superamas / Imagetanz preface (Vienna). Since 2002 dancer and choreographer at Pilottanz AERO dance festival (Amsterdam / Netherlands / 2000), EXPO 2000 (Hannover / Germany) and the festival Internacional de las Artes (Costa Rica / 1998).

Anna Scheer

born in Vienna. Training of Visual Performance at Dartington College of Arts. Stage camera for 'The Other is You' at Stationshouse Opera London. Produced interactive videos for kunmus graz, video projections and stage design for next liberty theatre.

Yolanda Espinoza Liendo

born in Linz. Dance training in various techniques. Since 2007 she is visiting Lessons of AIKO, as other Butoh – Lecutres (e.g. Hiromi Harada, Tadashi Endo). Member of the Butoh-dance company MayuKan.



nomad.theatre :: LABfactory

CREDITS

direction/ concept / general installation Thomas Jelinek

composition/sound environment Art Denissov. **performance/living installations** Magda Loitzenbauer, David Kleinl, Zeynep Buyrac, Harald Jokesch, Yolanda Espinoza. **visuals** Michael Loizenbauer. **stage camera / life video** Anna Scheer. Christina Hartl-Prager **life musician**

David Kleinl. **life musician in exposition** David Kleinl, Alexander Kemethofer, Stephan

Mühlbacher. **choreographic support** AIKO. **assistance** Ruth Schmid, Mira Turba. **technician**

sound Andreas Wiesbauer. **technical assistance** Katherina Mackowiak. **camera** Peter Hirsch.

photography Regina Mierzwa. **editing** Julia Lutz. **trailer** Ella Esque. **DVD production**

Emanuel Andel.

special thanks to 3Raum, DI Christoph Ilias, Tom Jirsa, Kazuko Kurosaki, Hubsi Kramar, Paul Luftensteiner, Johannes Rudnicki, Luke Baio, Linda Esslinger, Sky Unlimited - Elke Weilharter.

IMPRESSUM: nomad.theatre **Photografy** Regina Mierzwa

Thomas J. Jelinek

Mira Turba

nomad.theatre

Praterstrasse. 42/1/3

A-1020 Wien

Tel./Fax:

++43-1-214 55 81

Mobile:

++43-6764006809

++43-69915181978

Mail:

office@nomad-theatre.org

Websites:

www.nomad-theatre.org

www.labfactory.org

CONTACT